

THERMOPLASTIC HEATING TABLE

Models: 56250, 56375 & 56500

Fabrication Tools and Materials, Inc.

*Exclusively designed to give constant professional bends
while working with all types of thermoplastic materials*

*Acrylic • Polycarbonate • PETG • ABS • Styrene •
PVC • and More!*





Heating Table models 56250 / 56375 / 56500

Product Information / Assembly Instructions

PROUDLY MADE
IN THE USA

Congratulations! on your purchase of FTM's NEW Series 56000 Complete Heating System. The 56000 models are re-designed from the ground up and include some great new features. These new features include the all NEW QTC44 controller, a Unistrut Rail System with 56" x 48" working area, quick release Cam Clamp Tray Locks, Material Support with Stops, Integrated Frame Stops and a NEW Leg Kit.

With faster set-up and more adjustability, the 56000 models will **REDUCE FABRICATION TIMES.**

56000 MODELS:

- 4 individually controlled heating trays
- Capacitive Touch Keypad
- Built-in 3 function timer
- NEW Max Heat Feature
- Internal cooling fan
- Power percentage display for each tray
- NEW larger working area
- Powder Coated Steel Legs

ELECTRICAL INFORMATION:

- Controller ---- Q-Touch Capacitive Control
- Maximum load -----1800 watts / 15 Amp
- Input voltage / Hz. ----- 120v AC / 60 Hz.
- Current control range ----- 0 to 100%
- Fuse -----BK/MDA-15-R

DIMENSIONS & WEIGHT:

- 62" wide x 58" deep x 34" high --- Over all
- 48" wide x 56" deep ----- Working area
- 86 Lb. ----- Assembled weight

INSULATION:

- 1700°f Ultra Hi-Temperature
- Heat treated to reduce stress
- Sealed & PTFE coated working surface

HEATING TRAYS (4):

- Elements are Computer Profiled for precise heating
- Maximum Operating Temperature of **800°f.**
- Heating trays have a 1-3/4" center to center measurement when put side by side
- Model #56250 .165" dia. Elements #11009
- Model #56375 .260" dia. Elements #11003
- Model #56500 .315" dia. Elements #11007

MATERIAL THICKNESS GUIDE:

- 56250: .040" - .080" (1mm – 2mm)
- 56375: .080" - .156" (2mm – 4mm)
- 56500: .125" - .500" (3mm – 12mm)

Our Heating Systems have been exclusively designed to give constant professional bends while working with all types of thermoplastic materials. Thermoplastic sheets may be formed along a straight line by strip heating. These systems create straight line bends or folds, and are capable of heating material up to 1/2" thick. This Complete Heating System is controlled by the **QTC (Quick Touch Controller)** System. This control supplies infinite control of AC power over the full range of input voltage. A variable amount of power to load is applied by usage of a solid state **Micro Processor**. Adjustment of the input voltage accomplishes precise control allowing exact matching of power to load requirements producing a precision temperature control system.

To use, simply place material on the tray with the area to be formed directly above the heating element. Do not allow the sheet to come in direct contact with the heating element. Overheating will cause scorching and bubbling. If this occurs, decrease the temperature or time, you may also increase the distance between the material and the element. Allow the material to heat thoroughly until it softens or welts in the area to be formed. Bend gently to the desired angle keeping the heated side of the material on the outside of the bend, and hold firmly until cool.

Bending material before it is thoroughly heated will result in stress crazing (small internal fractures) or breaking along the bend. Overheating will cause the material to bubble or pick up the pattern of a jig, if one is used. It is advisable to practice on scrap material before heating a larger work piece.

Heating Table models 56250 / 56375 / 56500

Product Information / Assembly Instructions

ASSEMBLY INSTRUCTIONS



Tools Needed

- No.2 Phillips Screwdriver
- 7/16" Wrench
- Tape Measure
- Rubber Mallet
- 5/32" Hex Key (Included)

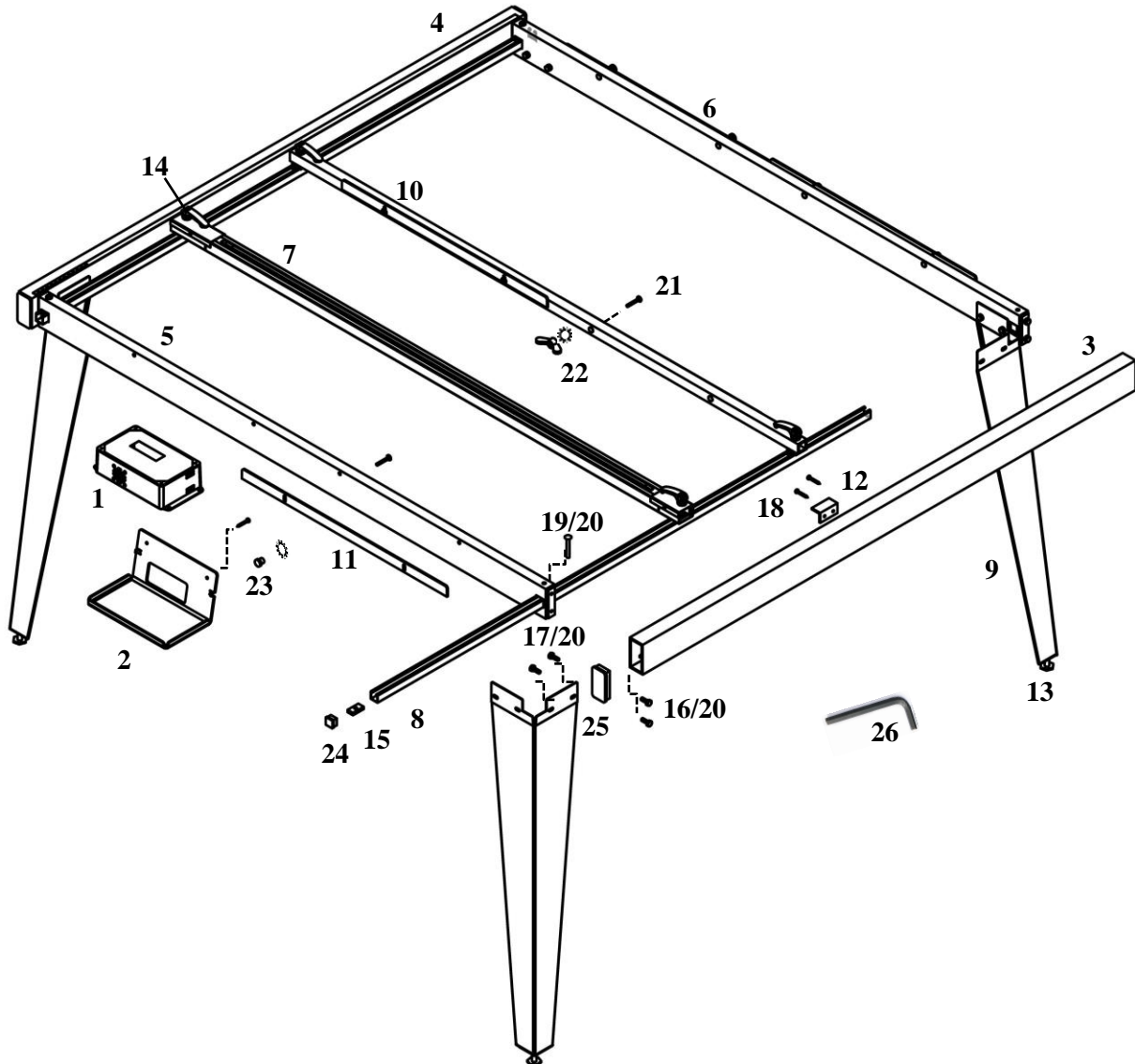
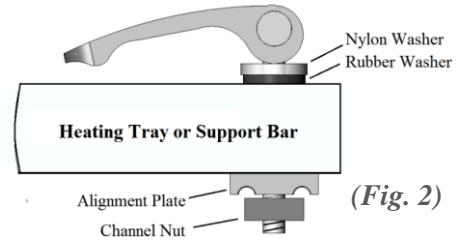
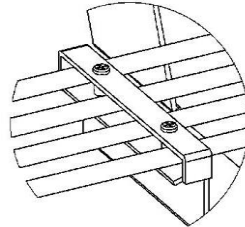
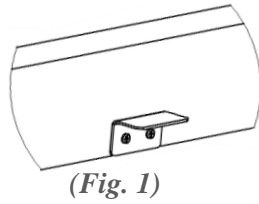

Heating Table models 56250 / 56375 / 56500

Product Information / Assembly Instructions

BOLT PACKAGE (A)

- 1) Attach Unistrut Supports (12) to inside center of Side Frames (3&4) as shown in (fig.1) using four #8 x 5/8" Self-tapping Screws (18) in pre-drilled holes.
- 2) Lay out Side Frames approximately 5 feet apart with rules facing up and holes facing each other.
- 3) Place Front and Back Frames (5&6) so the A/A, B/B, C/C & D/D labels match up with Side Frames. Bolt all four corners together using eight 1/4"-20 x 1/2" Hex Bolts (16) and eight 1/4" Split Washers (20). Do not tighten bolts at this time.
- 4) Square frame by cross measuring corner to corner and tighten all eight Hex Bolts.

BOLT PACKAGE (B)

- 5) Turn frame upside down. Fully thread in Leveling feet (13) to Legs (9). Attach Legs to inside corners by aligning holes in Legs with threaded holes in frame. Attach with eight 1/4"-20 x 3/4" Hex Bolts (17) and 1/4" Split Washers and tighten bolts.
- 6) Turn frame right side up and adjust Leveling Feet on Legs to level unit and prevent rocking.
- 7) Install Rectangle Tubing Caps (25) on ends of Side Frames by tapping gently with a rubber mallet.

BOLT PACKAGE (C)

- 8) Slide Unistruts (8) from outside of frame, open side up, through square holes in Front and Back Frames, until Unistruts are centered in frame.
- 9) Insert one channel nut (15) into each end of Unistruts. Secure Unistruts to frame using 1/4"-20 x 2" Round Head Bolts (19) and 1/4" Split Washers dropped down through Front and Back Frames and thread into channel nuts. Do **NOT** tighten at this time.

BOLT PACKAGE (D)

- 10) Install two Heating Trays (7), numbers 1 and 4, with cords on inside of Unistrut and on A/A side of frame by resting trays on far ends of Unistruts with the trays' alignment plate groves making contact with top of the Unistruts.
- 11) Drop one Channel Nut for each tray into each Unistrut. Secure tray to Unistruts by passing Cam Clamp Assemblies (14) down through tray ends and thread into Channel Nuts (fig.2). Adjust tightness and use Cam Clamps to lock and unlock trays to Unistruts. **(DO NOT OVER TIGHTEN)**
- 12) With both trays secured to Unistruts, finish tightening Unistruts to frame using the Hex Key (26) supplied.
NOTE: This insures proper tray alignment.
- 13) Install remaining trays 2 and 3 with Channel Nuts and Cam Clamp Assemblies as in step 9.

NOTE: It is important that all electrical wires from heating trays to QTC44 Controller (1) are routed under the Side Frame. Trays are numbered 1, 2, 3 & 4 to correspond with back of the Control Box. Do not plug into Control Box at this time.

BOLT PACKAGE (E)

- 14) Drop one Channel Nut in each Unistrut where Support/Stop Bar (10) will be used in frame. Install Support/Stop Bar with "cord side" on same side as tray cords. Secure to unistruts using Cam Clamp Assemblies by passing Cam Clamp Assemblies down through holes on each end of Support/Stop Bar and thread into Channel Nuts, adjust tightness and use Cam Clamps to lock and unlock Support/Stop Bar to Unistruts.

NOTE: Holes for Support/Stop Bar and Front/Back Frames are offset to match heated area on trays.

- 15) Attach two Stops (11) to Support/Stop Bar using four #10-24 x 1-1/2" Carriage Bolts (21) and #10-24 Wing Nuts with tooth washers (22). Stops can be placed on either side of Support/Stop Bar.
- 16) Attach two Stops to outside of one of the Front/Back Frames using four #10-24 x 1-1/2" Carriage Bolts and Clamp Knobs with tooth washers (23).

IMPORTANT NOTE: Do NOT use plastic Clamp Knobs inside frame near Heating Trays.

- 17) Install Square Tubing Caps (24) on ends of Unistruts.

MOUNTING TRAY and CONTROLLER

- 18) Move Heating Trays away from Front Frame. Mount Controller Tray (2) to left side of Front Frame (5) by lifting Controller Tray up behind frame until Tray Stops touch bottom of frame. Align the two pre-drilled holes in Front Frame with the two slotted holes in Controller Tray. Secure to frame using two #8 x 5/8" Self-tapping Screws.
- 19) Pass Heating Tray cords through Controller Tray and match the Heating Tray number to the corresponding number on the Controller and connect Heating Trays to Controller.
NOTE: See QTC44 Owner's Manual for connecting to Controller.
- 20) Place Controller in Controller Tray and secure heating tray cords to Controller Tray with the cord retainer, as shown in (fig.3).
- 21) Visually check to verify all components have been properly installed before connecting to power source.
- 22) **Sit back and enjoy a Job Well Done!**

Heating Table models 56250 / 56375 / 56500

Product Information / Assembly Instructions

Parts List		
Number	Description	Total Quantity
1	Controller	1
2	Controller Tray with self-tapping screw	1
3	Side Frame – RIGHT SIDE	1
4	Side Frame – LEFT SIDE (tray cord side)	1
5	Front Frame	1
6	Back Frame	1
7	Heating Trays*	4
8	Unistruts (57-3/8")	2
9	Legs	4
10	Support/Stop Bar	1
11	Stops	4
12	Unistrut Supports	2
13	Leveling Feet	4
14	Cam Clamp Assemblies	10
15	Channel Nuts	14
16	1/4"-20 x 1/2" Hex Bolts	8
17	1/4"-20 x 3/4" Hex Bolts	16
18	#8 x 5/8" Self-tapping Screws	4
19	1/4"-20 x 2" Round Head Bolts	4
20	1/4" Split Washers	28
21	#10-24 x 1-1/2" Carriage Bolts	8
22	#10-24 Wing Nuts & Tooth Washers	4
23	Clamp Knobs & Tooth Washers	4
24	Square Tubing Caps	4
25	Rectangle Tubing Caps	4
26	Hex Key	1

Date of purchase: _____

Model No.: _____

Ser. No.: _____

Bolt Package		Hardware for:				
A	B	Frame Kit				
C	D	Leg Kit				
E	Unistrut Rails					
Bolt Package Quantities		Heating Trays				
A	B	C	D	Support/Stop Bar		
2	4	4	8	2	2	
8	16	4	8	2	8	
4	16	4	4	4	4	
8	16	4	4	4	4	
4	4	4	4	4	4	
1	1	1	1	1	1	

* Part No. TT250 with Model 56250, TT375 with Model 56375, TT500 with Model 56500

RULES for SAFE OPERATION:

- Read and follow all instructions before using equipment.
- Burn Hazard; do not let bare skin come in contact with heating trays.
- Unplug from outlet when not in operation.
- This unit is not intended for use on wet or moist surfaces as it could result in electrical shock.
- Keep combustible materials away from unit.
- Do not leave any material on unit unattended at any time.
- Use on a level surface with exposed heating elements facing up (do not use upside down).
- Do not use outdoors.

WARRANTY / LIMITATION on LIABILITY

For 90 days from the date of original purchase, FTM will repair or replace any defect in material or workmanship. This warranty excludes insulation material. FTM will not be liable for loss or damage to property or any incidental or consequential loss or expense from property damage due directly or indirectly from the use of this product. This warranty does not include damage to the product resulting from accident, misuse, improper installation or operation, or unauthorized repair or alteration. Warranty service is available by sending the product to FTM's service center with all transportation charges paid. A RMA Number is required before returning any merchandise. FTM's packaging meets all UPS standards in the event of a claim. Authorized returns must be received in "as shipped" condition. Any freight damage that occurs in the return shipment is the responsibility of the shipper or the authorized distributor. No claims allowed unless filed within 5 days from delivery date. Return goods are subject to a 10% restocking charge and a RMA Number is required. Freight charges are not refunded unless agreed upon by seller prior to return of goods. FTM has final determination on all returned goods and credits. FTM's terms and conditions supersede all other previous terms and conditions.